

THE ROAD ZIPPER SYSTEM®

FOR MANAGED LANES



The Road Zipper is designed to cost effectively increase capacity and reduce congestion by making more efficient use of new or existing roadways. Applications include high volume highways where additional right-of-way may not be available, where environmental concerns may exist, or where the lack of funding may slow or inhibit support for new construction.

The system can transfer a mile (1.6 km) of high performance concrete barrier up to two lanes in less than 10 minutes, offering DOT's an innovative strategy for making our congested highway system more efficient, safe and functional. These benefits can be realized in less than one year and at a fraction of the cost of new construction.

The Road Zipper provides a quick and cost-effective solution for highway capacity improvements, without having to wait for time consuming study reviews. It allows DOT's to preserve their corridor options (Managed Lanes, Bus Rapid Transit (BRT), Reversible Lanes, Contraflow, HOV and HOT Lanes), while providing a "fast-build" solution for mitigating congestion.

MOVEABLE MEDIANS

The moveable median is perhaps the most simple way of optimizing highway capacity. In this case, there is no fixed barrier on the highway, and the moveable barrier is the only barrier. The barrier is moved back and forth multiple times per day to reconfigure the roadway based on the needs of peak traffic. The moveable median is most commonly applied to bridges and other highway applications with few center structures (viaducts or elevated structures also fit this model).



A moveable median creates a 4/3, 3/4 traffic pattern using 7 lanes

Ben Franklin Bridge, Philadelphia, PA

MOVEABLE MEDIAN CROSS SECTIONS



AM Peak Traffic



PM Peak Traffic

REDUCES CONGESTION

The Road Zipper gives more lanes to the peak traffic direction for AM and PM commuters.

INCREASES SAFETY

Positive barrier protection eliminates the possibility of cross over, head-on accidents.

"FAST-BUILD" SOLUTION

New construction can take years for planning and environmental reviews. The Road Zipper can often be deployed in less than one year.

GREEN BENEFITS

Benefits include improved air quality, improved fuel efficiency, and reduced atmospheric CO₂.

QUALIFIES FOR MAP-21

Federal funds are available to help create managed lanes in the US.

STRETCHES TRANSPORTATION BUDGETS

According to the FHWA, new urban freeway construction can cost up to \$15.4 million per urban lane mile. The Road Zipper is a fraction of this cost.

CONTRAFLOW LANES

A single moveable median barrier may not be practical in some situations. This may be because the two directions of the highway are on different elevations or structures, because there is a substantial existing median barrier, or because there are many center structures. In these cases, two moveable walls are used, one on each side of the roadway. The barrier is deployed during off-peak traffic hours, and traffic from the peak side of the highway is allowed to cross over and use the new lane, thus gaining additional capacity. This system provides the same optimization and efficiency as a moveable median despite the geometric challenges.



I-30, Dallas, TX

CONTRAFLOW CROSS SECTIONS

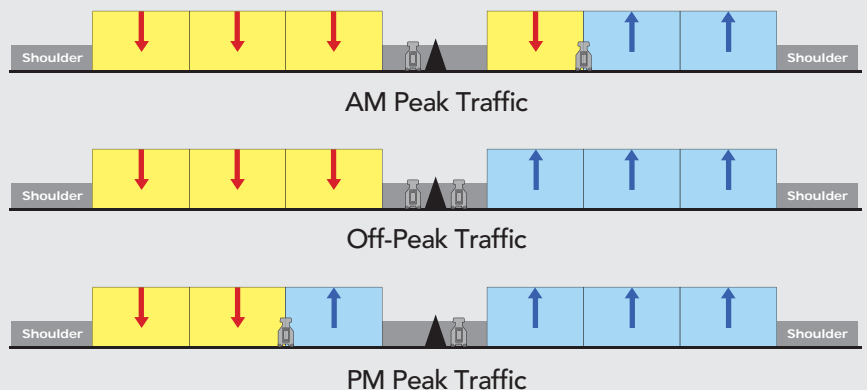

PHYSICAL SPECIFICATIONS

18" Concrete Reactive Tension System (CRTS)
 Heavily reinforced concrete barrier sections have superior deflection and vehicle stability when compared to Temporary Concrete Barrier.

- Permanent Deflection**
 MASH TL-3: 39 in. (990mm)
 NCHRP 350 TL-3: 24 in. (610mm)
 EN 1317-2 N2: 27.5 in. (700mm)
 EN 1317-2 H2: 55 in. (1.4m)
 EN 1317 (TB21): 10 in. (260mm)
 EN 1317 (TB41): 37.5 in. (950mm)

Mass of each barrier element: Approx. 1500 lbs (680 kg)

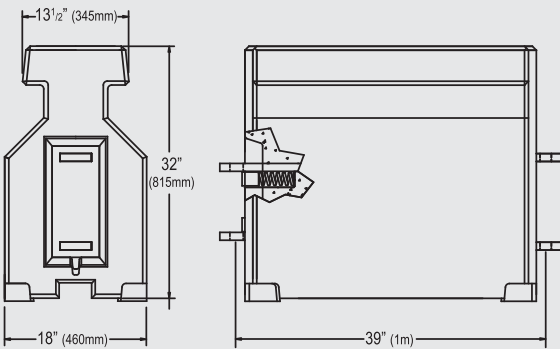

13" Steel Reactive Tension System (SRTS)
 High strength steel structure filled with concrete and Reactive Tension elements resulting in the narrowest profile with low deflection. Ideal for use where low deflection is required and minimum lane width exists.

- Permanent Deflection**
 NCHRP 350 TL-3: 27.5 in. (700mm)

Mass of each barrier element: Approx. 1500 lbs (680 kg)

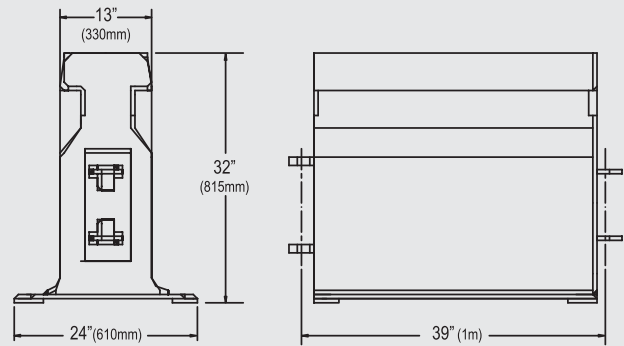

BARRIER TRANSFER MACHINE			
Transfer Speed	8 - 10 mph (13 - 16 km/h)	Max. Single Transfer	30 ft (9.1 m)
Roading Speed	20 mph (32 km/h)	Transfer Time	1 mile (1.6 km) in 6 - 8 minutes

ROAD ZIPPER CASE STUDY

Dallas, TX I-30

- 15,000 commuters daily in the HOV lanes
- Saves 14 minutes per trip = 1 million hours per year
- Benefit to Cost ratio of 6.5 to 1
- Helps Dallas meet air quality goals
- Average US vehicle occupancy = 1.1, Dallas HOV = 2.9
- Most cost-effective way to mitigate congestion (system expanded 3 times)



Lindsay Transportation Solutions Sales & Service • 18135 Burke St., Elkhorn, NE 68022
 U.S. Toll Free: 888.800.3691 • www.lindsaytransportationsolutions.com